

2011

GAS CATALOG

FLO~PRO
PERFORMANCE EXHAUST

<u>Make/Model</u>	<u>Page Number</u>
Cadillac Escalade	3
GMC Sierra/Silverado	4-8
GMC Yukon Denali	9
Dodge Ram	10
Ford F150/Lincoln LT	11-12
Hummer	13
Jeep Wrangler/Rubicon	14
Nissan Frontier	15
Nissan Titan	16
Toyota Tacoma	17
Toyota Tundra	18

FLO~PRO

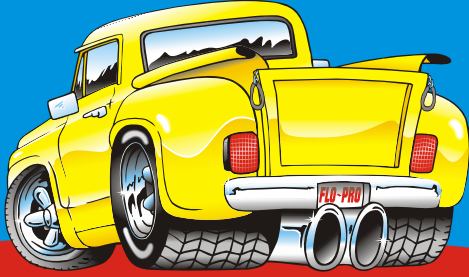

Performance Exhaust

Put Pride in your Ride

FLO~PRO introduces its new performance exhaust systems for gas power engines. Like our large diameter 4" and 5" diesel systems, our gas systems are all performance and save you the stress from interior cab noise synonymous with performance exhaust and big block engines.



GM 6.0L & 8.1L

All vehicles are not created equal so using the same muffler really isn't logical. Each system is custom tuned and fit for the specific vehicle. Performance is our #1 priority, but controlling interior noise levels is also important. At FLO~PRO, we're about making power not just noise.



O.E. restricted to 1" Y on Titan



Full flowing true dual mandrel bends on Titan.

Every detail was considered including eliminating restrictive O.E. Y transitions and using longer luster double wall stainless tips. Our systems are designed for excellent fit and easy installation. Made with stainless steel materials for looks and longevity. Large diameter mandrel bent singles, rear duals and side duals on most applications.

Power without Punishment

CADILLAC ESCALADE

62008

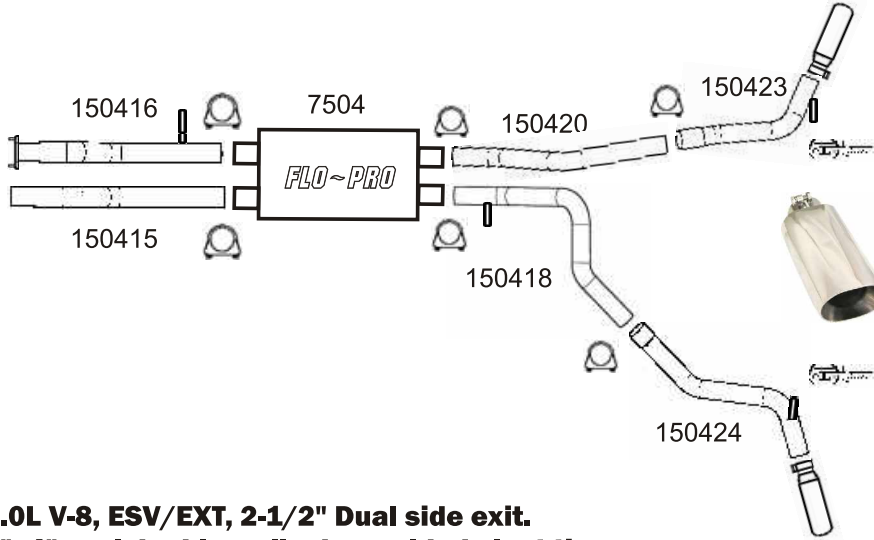

**03-06 6.0L V-8, ESV/EXT, 2-1/2" Dual side exit.
3"x4" oval double wall edge welded slant tip**



GMC SIERRA/CHEVROLET SILVERADO LIGHT DUTY

62000

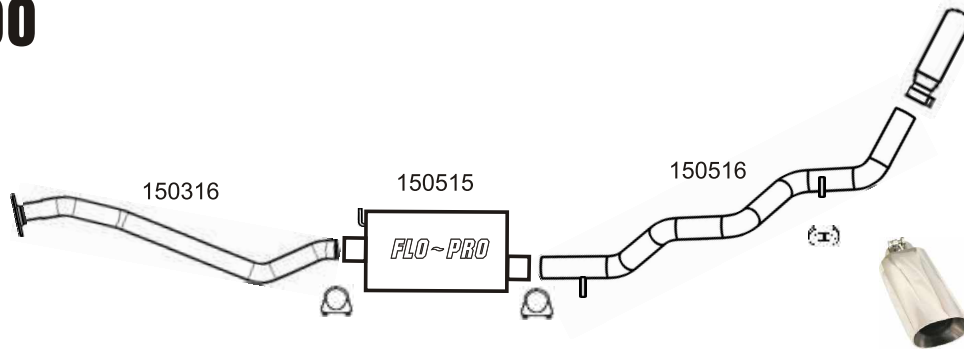

**03-07* 4.3L V6, 4.8L/5.3L V8, EC/6.5'Box, 3" single side exit.
3"x4" oval double wall edge welded slant tip**

*** Fits 2007 Classic Models only.**

62001

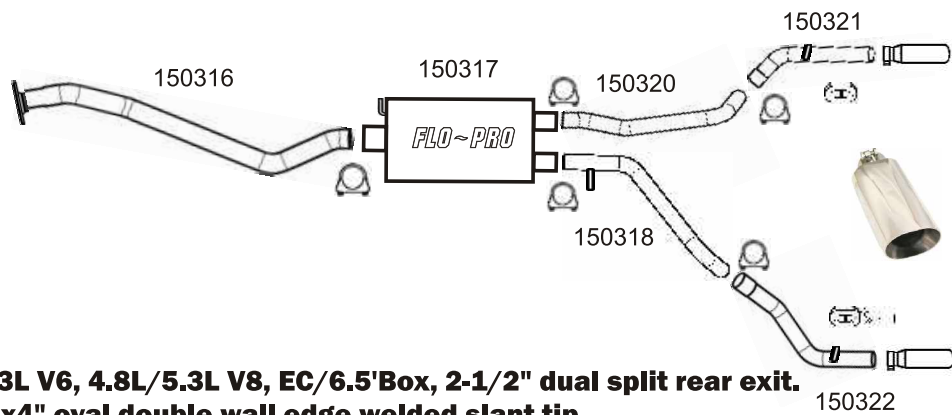

**03-07* 4.3L V6, 4.8L/5.3L V8, EC/6.5'Box, 2-1/2" dual split rear exit.
3"x4" oval double wall edge welded slant tip**

*** Fits 2007 Classic Models only.**

62002

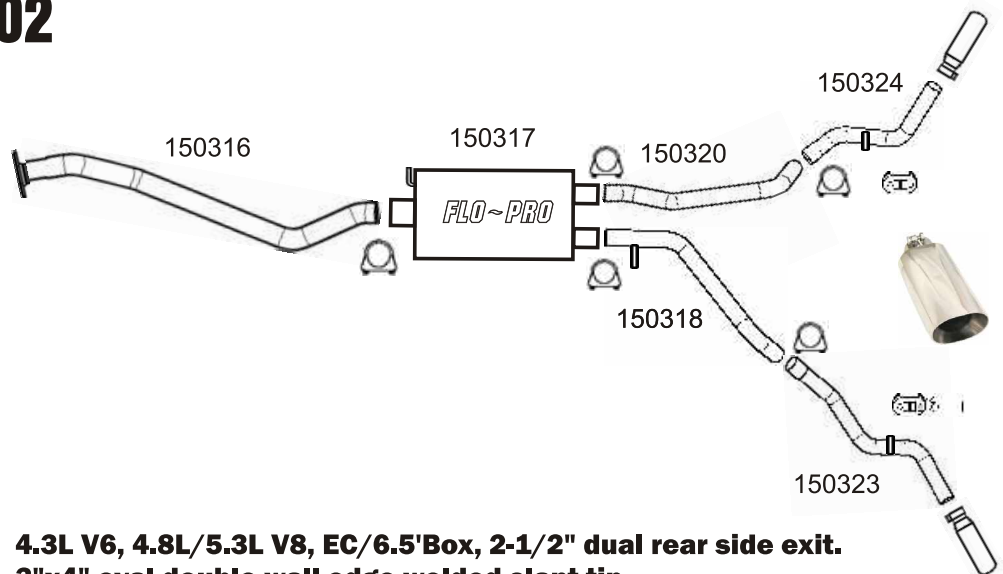

**03-07* 4.3L V6, 4.8L/5.3L V8, EC/6.5'Box, 2-1/2" dual rear side exit.
3"x4" oval double wall edge welded slant tip**

*** Fits 2007 Classic Models only.**

GMC SIERRA/CHEVROLET SILVERADO LIGHT DUTY

62013

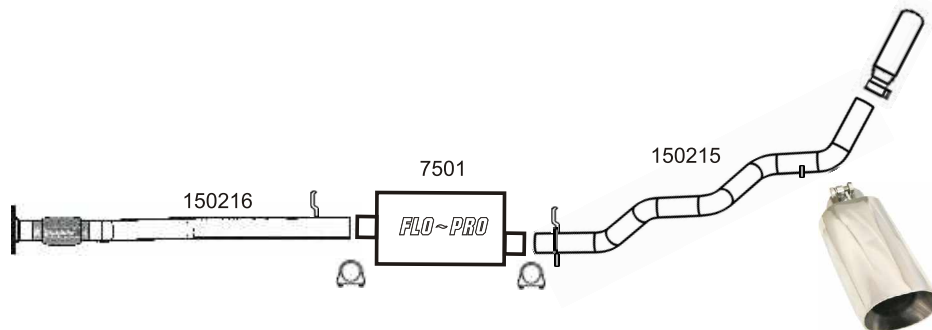

**07NBS-08 4.3L V6, 4.8L/5.3L V8, EC/6.5'-CC/5.8', 3" single side exit.
3"x4" oval double wall edge welded slant tip**

62014

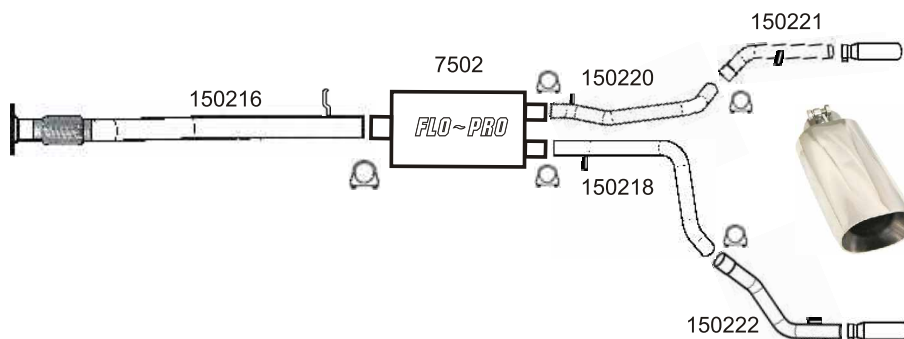

**07NBS-08 4.3L V6, 4.8L/5.3L V8, EC/6.5'-CC/5.8', 2-1/2" dual rear exit.
3"x4" oval double wall edge welded slant tip**

62015

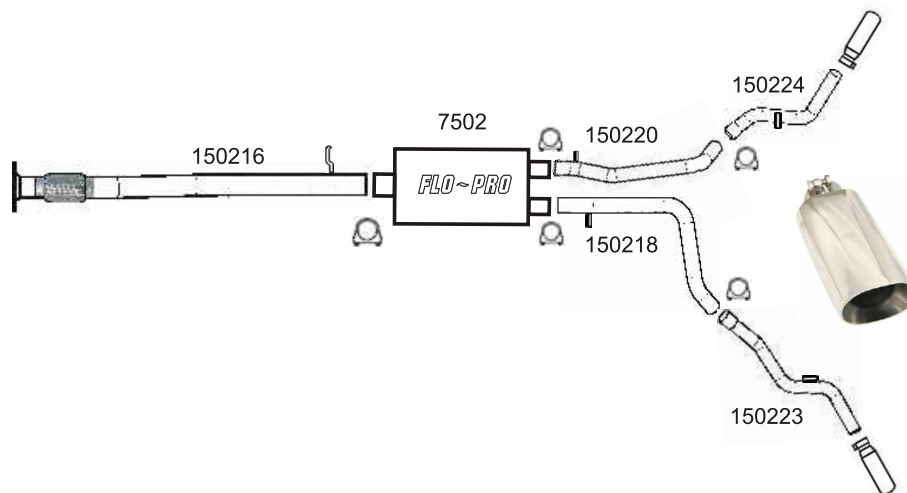

**07NBS-08 4.3L V6, 4.8L/5.3L V8, EC/6.5'-CC/5.8', 2-1/2" dual side exit.
3"x4" oval double wall edge welded slant tip**

GMC SIERRA/CHEVROLET SILVERADO LIGHT DUTY

62028

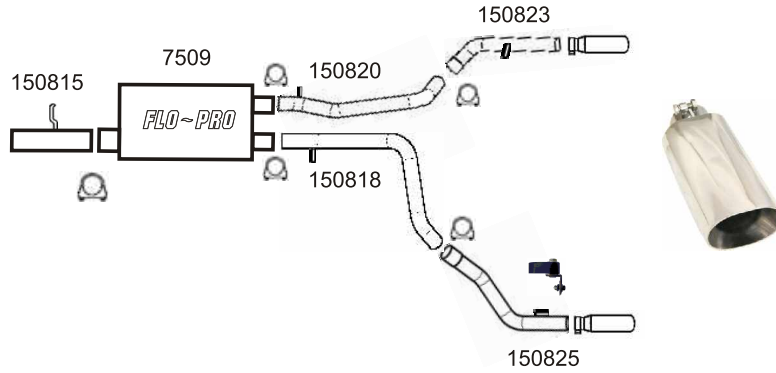

**08-10 6.2L V8, CC/SB', 3" dual rear exit.
3"x4" oval double wall edge welded slant tip**

62029

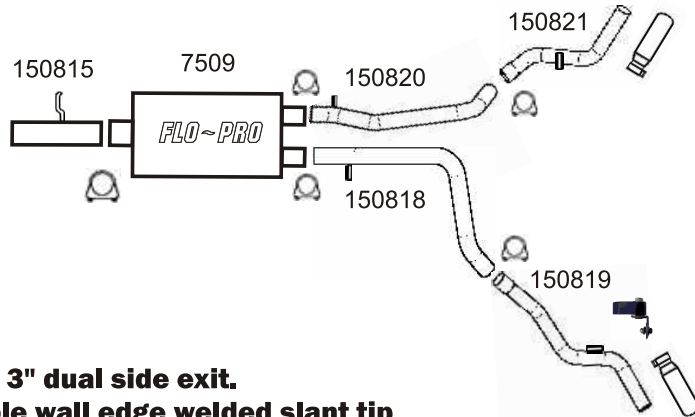

**08-10 6.2L V8, CC/SB, 3" dual side exit.
3"x4" oval double wall edge welded slant tip**

GMC SIERRA/CHEVROLET SILVERADO HEAVY DUTY

62003

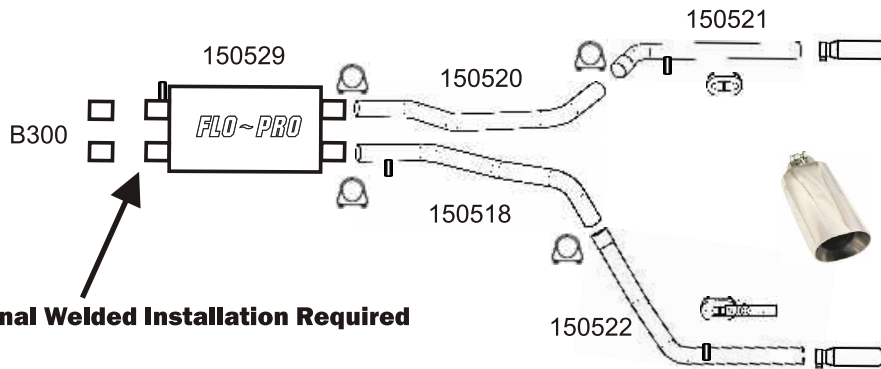

Professional Welded Installation Required

**03-06* 6.0L V8, EC-CC/SB, 2-1/2" dual split rear exit.
3"x4" oval double wall edge welded slant tip**

62004

Professional Welded Installation Required

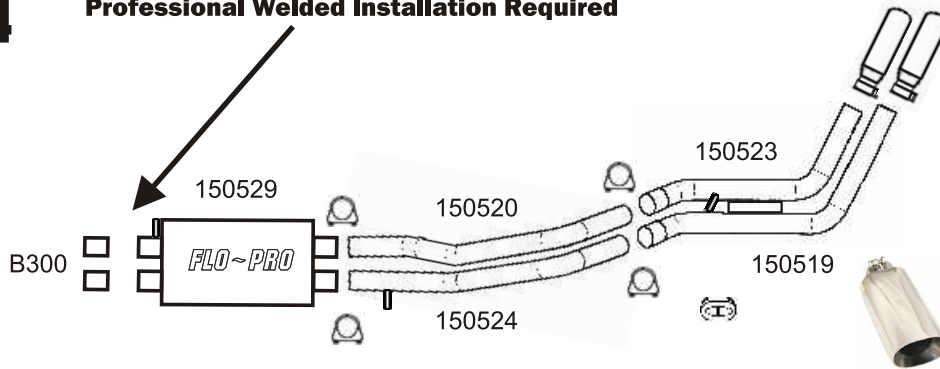

**03-06* 6.0L V8, EC-CC/SB, 2-1/2" dual same side rear exit.
3"x4" oval double wall edge welded slant tip**

62020

Professional Welded Installation Required

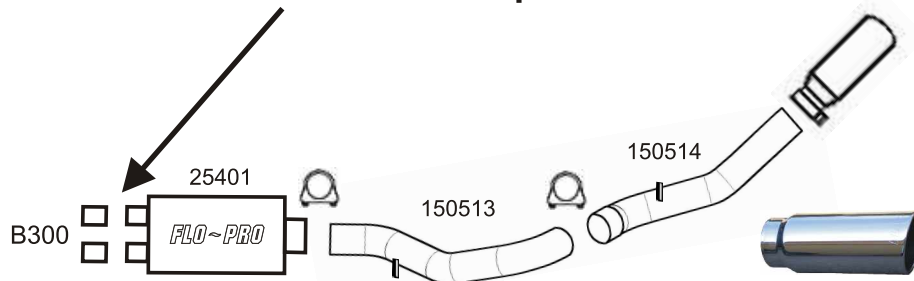

**03-06 6.0L V8, EC-CC/SB, 4" single side exit.
5" rolled angle cut tip**

GMC SIERRA/CHEVROLET SILVERADO HEAVY DUTY

62024

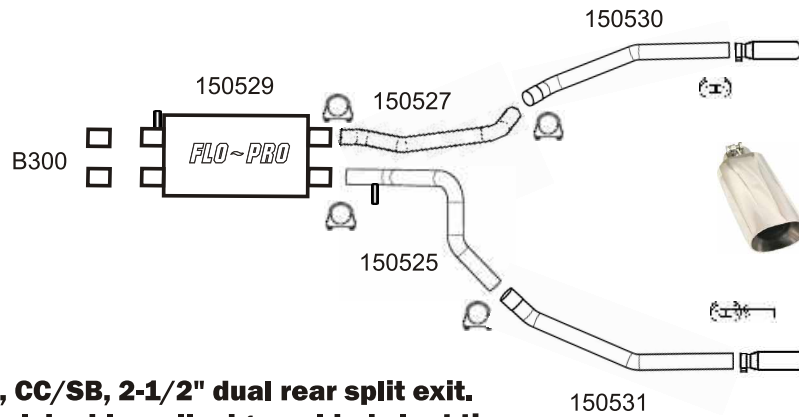

**07 Classic 6.0L, V8, CC/SB, 2-1/2" dual rear split exit.
3"x4" oval double wall edge welded slant tip**

62023

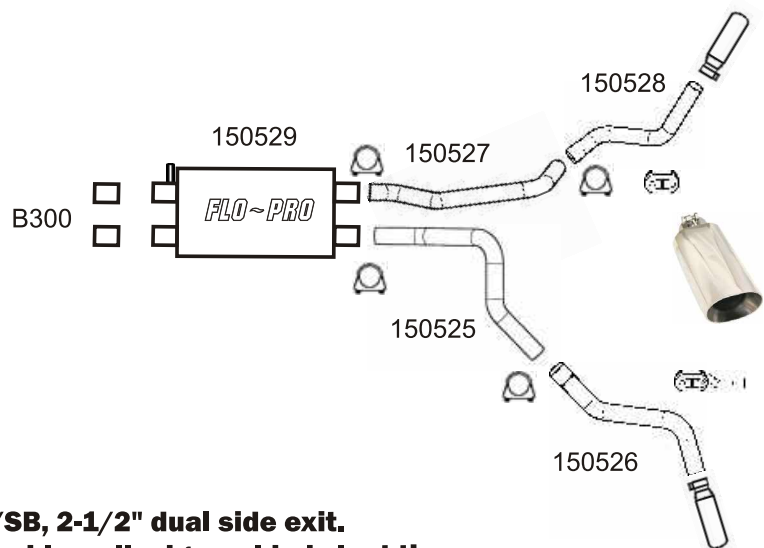

**07 Classic 6.0L, V8, CC/SB, 2-1/2" dual side exit.
3"x4" oval double wall edge welded slant tip**



GMC YUKON DENALI XL

62008

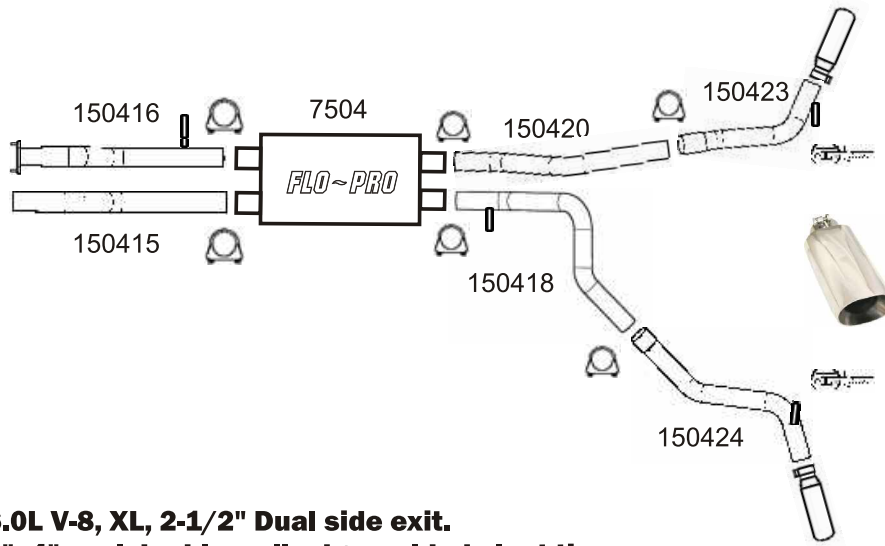

**03-06 6.0L V-8, XL, 2-1/2" Dual side exit.
3"x4" oval double wall edge welded slant tip**

DODGE RAM

62025

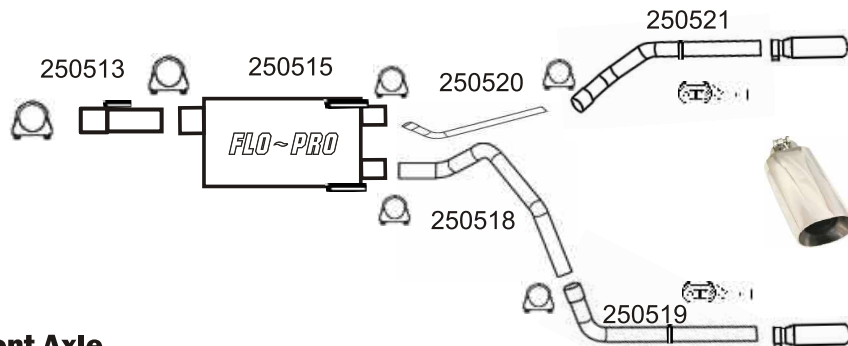

06-08 Solid Front Axle
1500 5.7L, V8, 4WD, SC/CC/MC - SB-LB, 2-1/2" dual split rear exit.
3"x4" oval double wall edge welded slant tip

62026

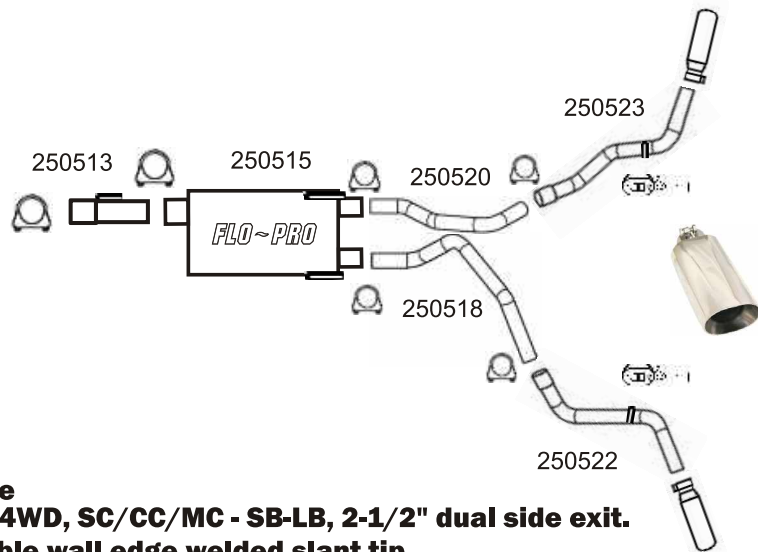

06-08 Solid Front Axle
1500 5.7L, V8, 4WD, SC/CC/MC - SB-LB, 2-1/2" dual side exit.
3"x4" oval double wall edge welded slant tip



FORD F150/LINCOLN LT

62005

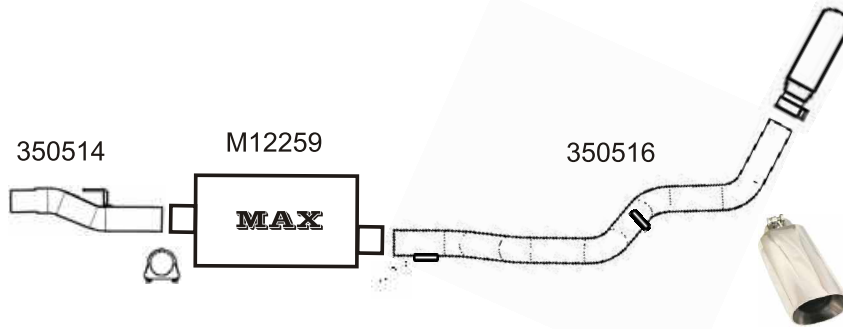

**05-10 4.6L/5.4L V8 EC-CC/SB, 3" single side exit.
3"x4" oval double wall edge welded slant tip**

62006

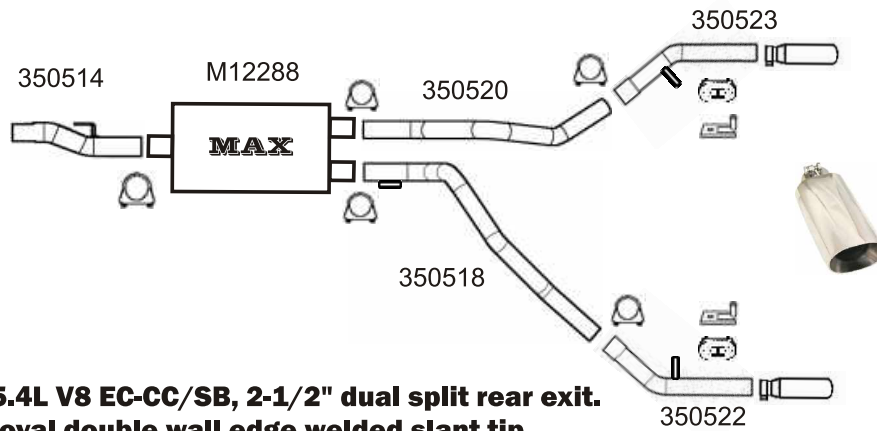

**05-08 4.6L/5.4L V8 EC-CC/SB, 2-1/2" dual split rear exit.
3"x4" oval double wall edge welded slant tip**

62007

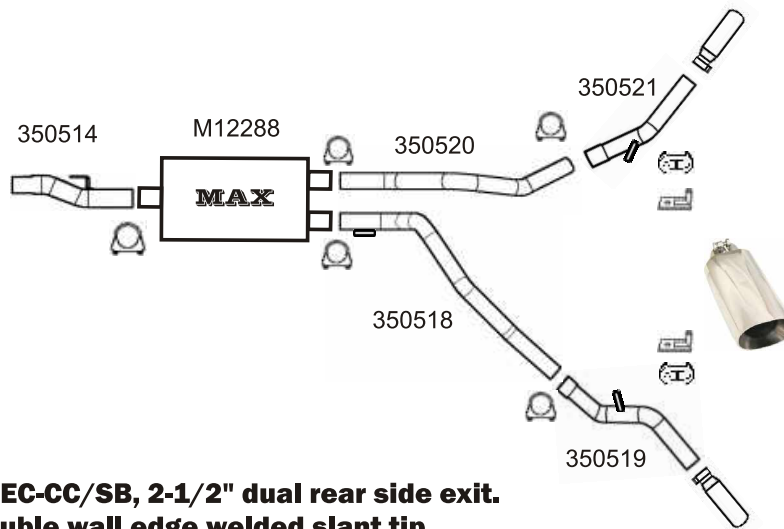

**05-08 4.6L/5.4L V8 EC-CC/SB, 2-1/2" dual rear side exit.
3"x4" oval double wall edge welded slant tip**

FORD F150/LINCOLN LT

62030

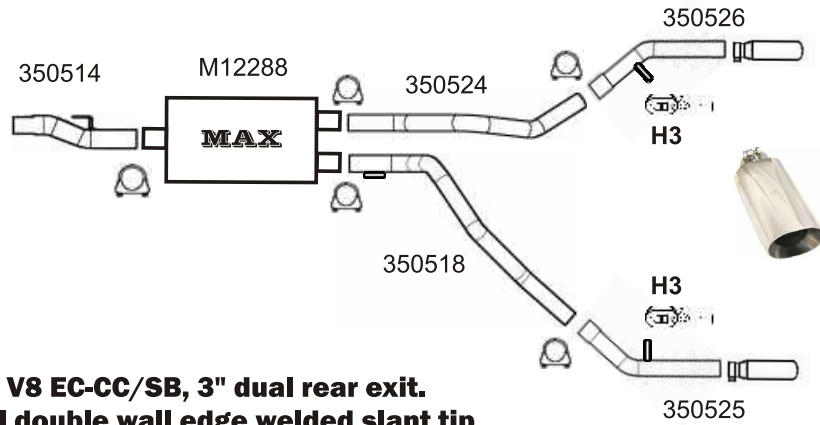

**09-10 4.6L/5.4L V8 EC-CC/SB, 3" dual rear exit.
3"x4" oval double wall edge welded slant tip**



HUMMER H2

62019

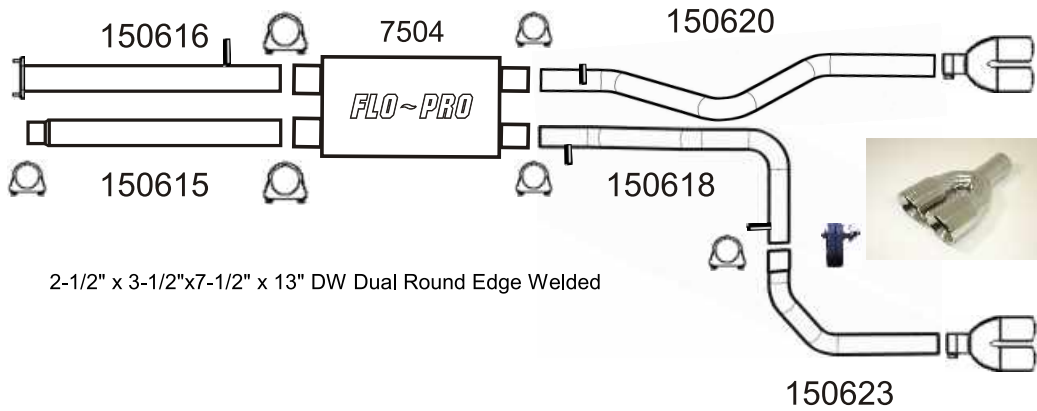

2-1/2" x 3-1/2"x7-1/2" x 13" DW Dual Round Edge Welded

**03-06 6.0L V-8, H2 & H2T Non Air Suspension Models,
2-1/2" Dual Split Rear exit. 2-1/2"x3-1/2"x7-1/2" DW Dual Round Tip**



JEEP WRANGLER UNLIMITED/RUBICON

62021

07-08 3.8L V-6, Jeep Wrangler Unlimited 4dr., 2-1/2" Dual rear exit.
3-1/2"x7-1/2" dual round double wall edge welded slant tip

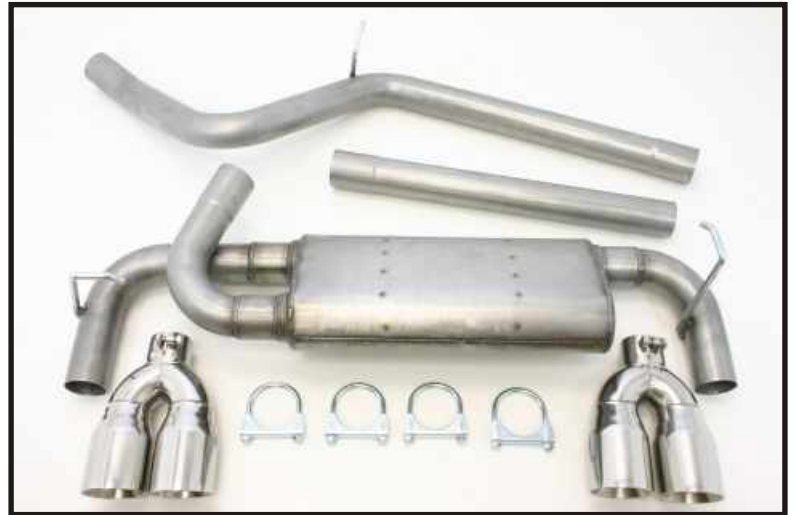
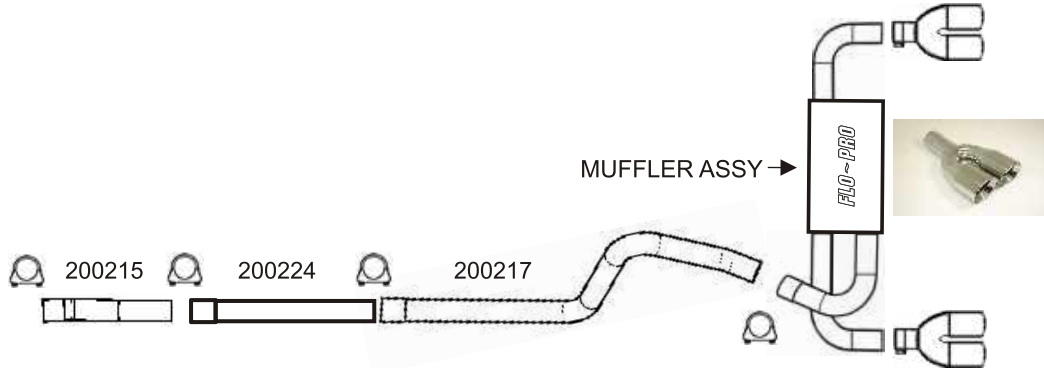

NISSAN FRONTIER

62022

**05-08 4.0L V-6, Frontier, 3" Single side exit.
3"x4" oval double wall edge welded slant tip**

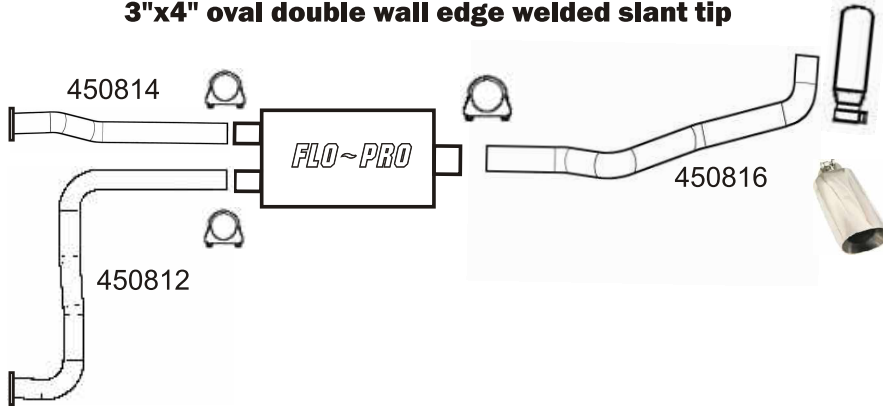

NISSAN TITAN

62018

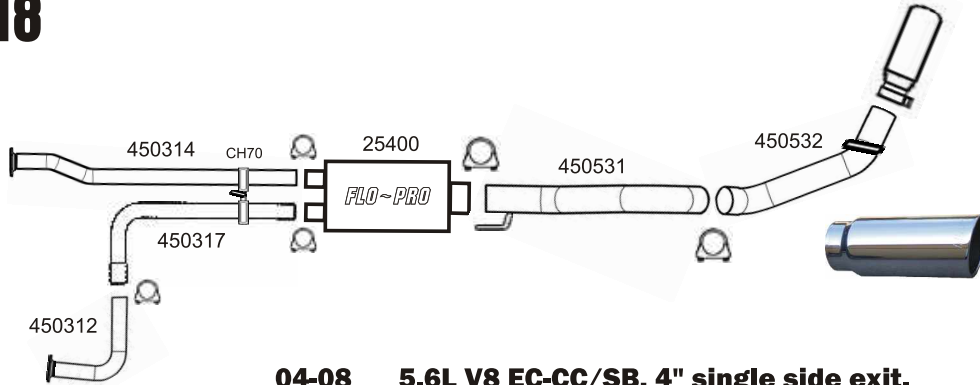

**04-08 5.6L V8 EC-CC/SB, 4" single side exit.
5" Rolled Edge 15 Degree Angle Cut tip**

62016

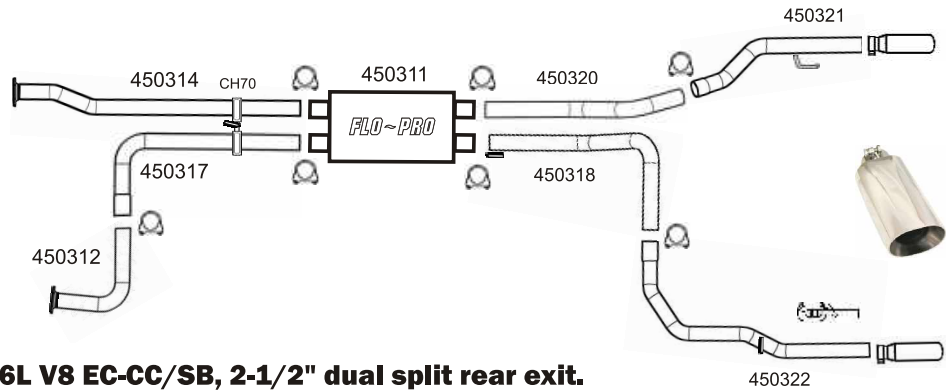

**04-08 5.6L V8 EC-CC/SB, 2-1/2" dual split rear exit.
3"x4" oval double wall edge welded slant tip**

62017

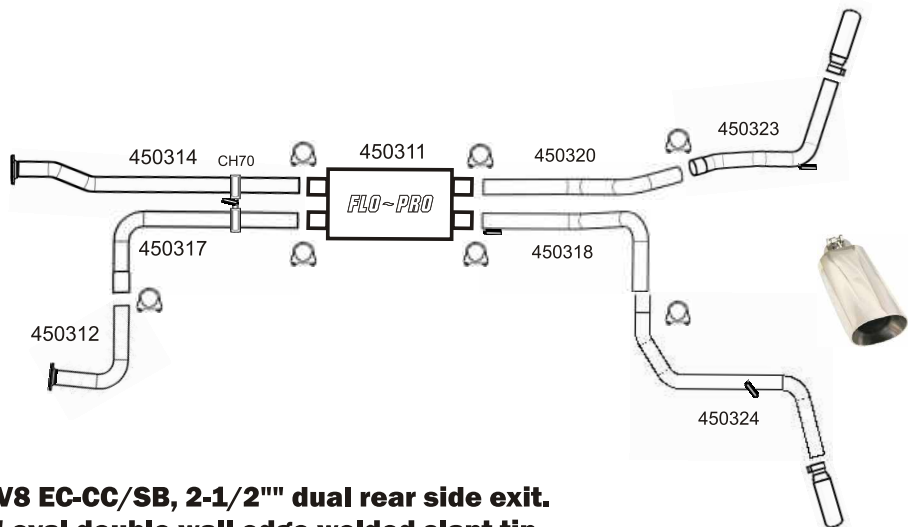

**04-08 5.6L V8 EC-CC/SB, 2-1/2" dual rear side exit.
3"x4" oval double wall edge welded slant tip**

TOYOTA TACOMA

62009

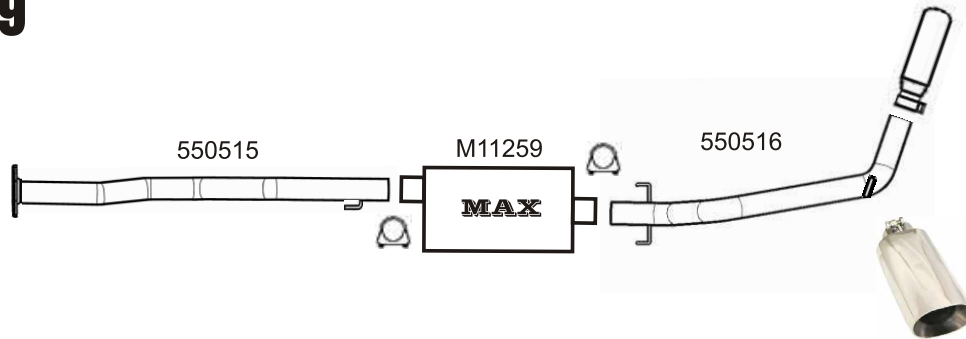

**05-08 2.7L I4/4.0L V6 Double Cab/LB, 3" single side exit.
3" x 4" oval double wall edge welded slant tip**

62010 Y-PIPE ELIMINATION SYSTEM

Professional Installation Required

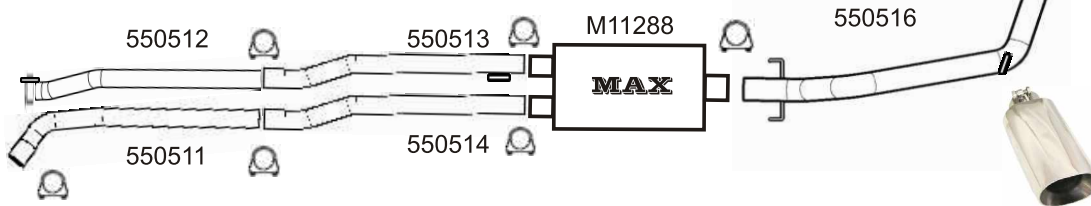

**05-08 4.0L V6 Double Cab/LB, 3" single side exit.
3" x 4" oval double wall edge welded slant tip**



TOYOTA TUNDRA

62027

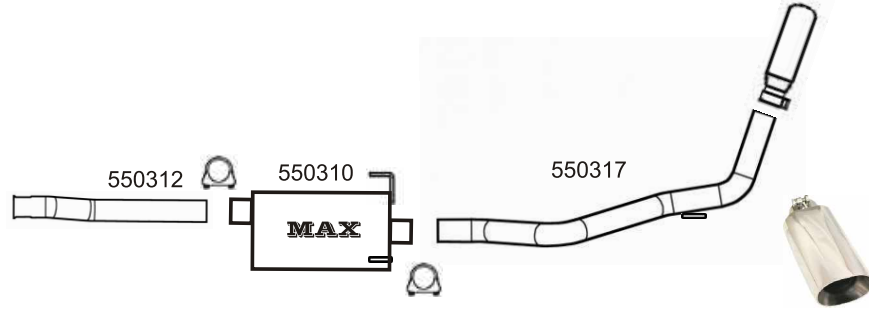

**00-03 3.4L V6 & 4.7L V8 CC/SB, 3" single side exit.
3" x 4" oval double wall edge welded slant tip**

62011

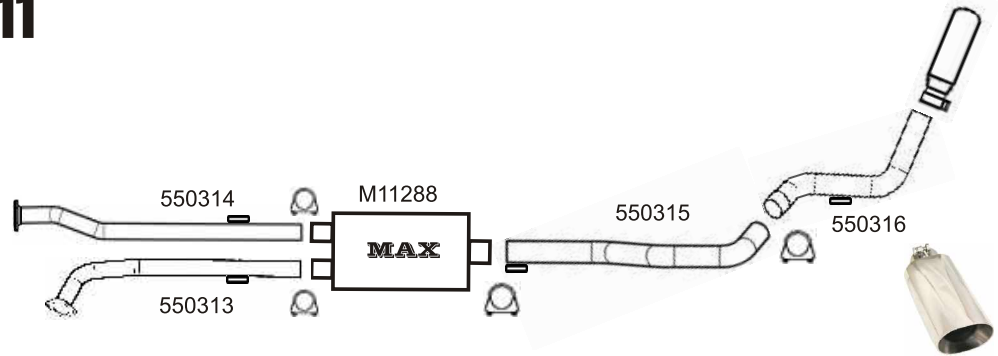

**07-08 5.7L V8 RC/LB - DC/SB, 3" single side exit.
3" x 4" oval double wall edge welded slant tip**

62012

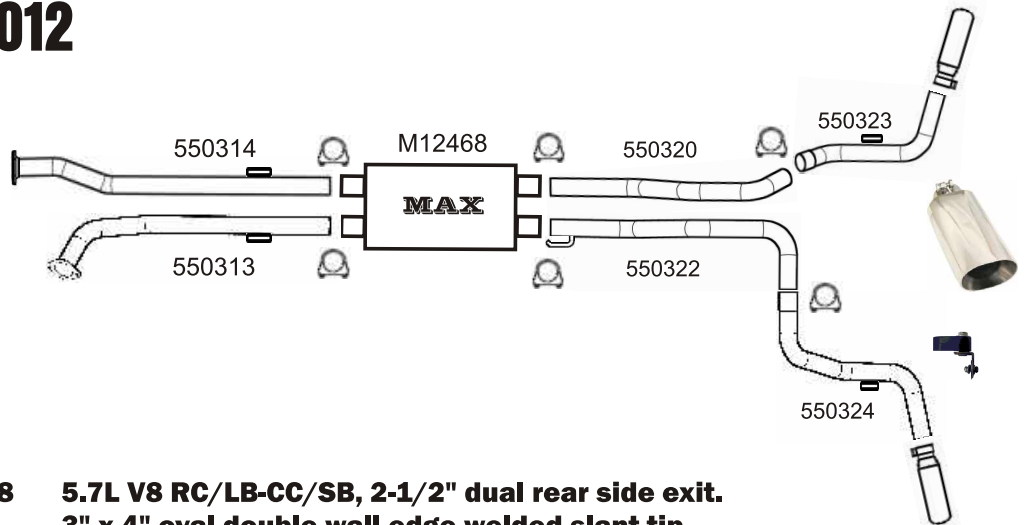

**07-08 5.7L V8 RC/LB-CC/SB, 2-1/2" dual rear side exit.
3" x 4" oval double wall edge welded slant tip**



FLO~PRO

PERFORMANCE EXHAUST

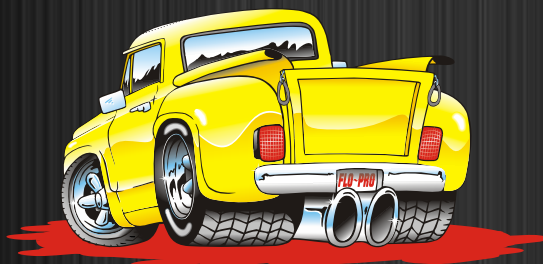

Printed 11APR25

WWW.FLOPRO.COM